

## High accuracy synchronizing, flow divider-combiner valve

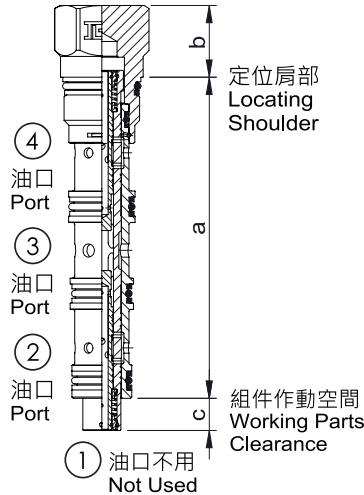

閥類型符號 SYMBOL  
J-FS\*\*

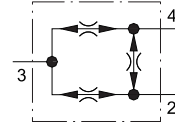

插裝閥尺寸

	a	b	c
J-FSAS	85.1	19.1	16.5
J-FSBS	85.1	19.1	16.5
J-FSER	114.3	24.6	14.2

### 性能曲線

### PERFORMANCE CURVES

分流比例 Split	分流精度		最大流量差異 Maximum Possible Flow Variation L/min	
	進油流量 Input Flow L/min	精度 Rated Accuracy		
J-FSAS				
50 : 50	最大進油 Max rated	6	±2.0%	2.9-3.1
	最小進油 Min rated	1	±3.5%	0.47-0.54
同步流量 Synchronizing Flow			0.6-1.0	
J-FSBS				
50 : 50	最大進油 Max rated	12	±2.0%	5.8-6.2
	最小進油 Min rated	2.5	±3.0%	1.2-1.3
同步流量 Synchronizing Flow			0.6-1.2	

分流比例 Split	分流精度		最大流量差異 Maximum Possible Flow Variation L/min	
	進油流量 Input Flow L/min	精度 Rated Accuracy		
J-FSER				
50 : 50	最大進油 Max rated	60	±2.0%	28.8-31.2
	最小進油 Min rated	12	±3.0%	5.6-6.4
同步流量 Synchronizing Flow			3.4-6.6	

最大流量差異:分流集流口之間的壓差為 350 kgf/cm<sup>2</sup>。  
分流模式時較高壓側可得較大流量,集流模式時較高壓側可得較小流量。

The maximum possible variation is at 350 kgf/cm<sup>2</sup> differential between legs with the high pressure leg being the higher flow in dividing mode and the lower flow in combining mode.

### 規格說明

### SPECIFICATION

型式 MODEL	最高使用壓力 MAX. OPERATING PRESSURE (kgf/cm <sup>2</sup> )	最大流量 MAX. FLOW L/min	安裝扭矩 MOUNTING TORQUE N·m	成型孔 CAVITY	重量 WEIGHT kg
J-FSAS	350	1-6	41-47	T-31A	0.16
J-FSBS		2.5-12			
J-FSER		12-60	203-217		

### 型號說明

### HOW TO ORDER

## J - FSAS - A - X

控制方式 CONTROL  
X : 不可調 NOT ADJUSTABLE

流量分配比 FLOW SPLIT  
A : 50/50

閥規格 VALVE SIZE  
FSAS : 1-6 L/min      FSBS : 2.5-12 L/min  
FSER : 12-60 L/min

系列編號 SERIES NUMBER

## Synchronizing, flow divider-combiner valve

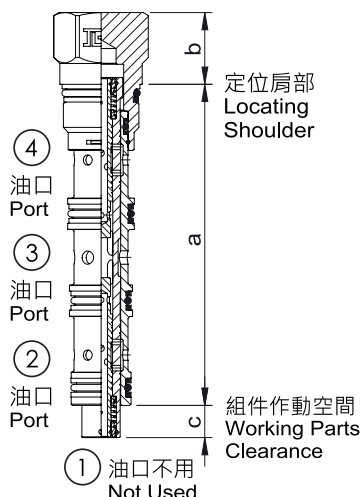

閥類型符號 SYMBOL  
J-FS※S

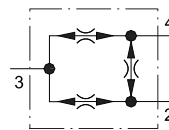

插裝閥尺寸

	a	b	c
J-FSCS	85.1	19.1	16.5
J-FSES	114.3	24.6	25.1

### 性能曲線

### PERFORMANCE CURVES

分流比例 Split	分流精度		最大流量差異 Maximum Possible Flow Variation L/min	
	進油流量 Input Flow L/min	精度 Rated Accuracy		
J-FSCS				
50 : 50	最大進油 Max rated	30	±2.5%	14.3-15.8
	最小進油 Min rated	6	±4.5%	2.73-3.27
同步流量 Synchronizing Flow			0.94-2.46	

分流比例 Split	分流精度		最大流量差異 Maximum Possible Flow Variation L/min	
	進油流量 Input Flow L/min	精度 Rated Accuracy		
J-FSES				
50 : 50	最大進油 Max rated	120	±2.5%	57-63
	最小進油 Min rated	23	±4.5%	10.5-12.5
同步流量 Synchronizing Flow			3.4-6.6	

最大流量差異: 分流集流口之間的壓差為 350 kgf/cm<sup>2</sup>。分流模式時較高壓側可得較大流量, 集流模式時較高壓側可得較小流量。  
The maximum possible variation is at 350 kgf/cm<sup>2</sup> differential between legs with the high pressure leg being the higher flow in dividing mode and the lower flow in combining mode.

### 規格說明

### SPECIFICATION

型式 MODEL	最高使用壓力 MAX. OPERATING PRESSURE (kgf/cm <sup>2</sup> )	最大流量 MAX. FLOW L/min	安裝扭矩 MOUNTING TORQUE N·m	成型孔 CAVITY	重量 WEIGHT kg
J-FSCS	350	6-30	41-47	T-31A	0.16
J-FSES		23-120	203-217	T-33A	0.66

### 型號說明

### HOW TO ORDER

## J - FSCS - A - X

控制方式 CONTROL  
X : 不可調 NOT ADJUSTABLE

流量分配比 FLOW SPLIT  
A : 50/50

閥規格 VALVE SIZE  
FSCS : 6-30 L/min  
FSES : 23-120 L/min

系列編號 SERIES NUMBER