

Pilot operated, pressure reducing/relieving valve

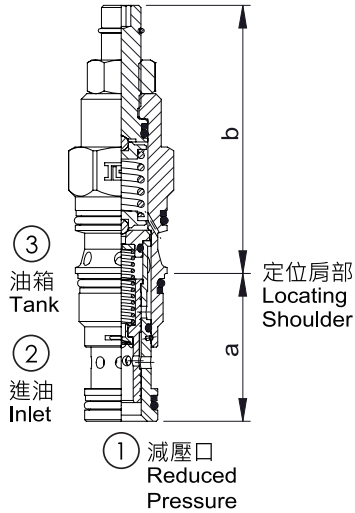

閥類型符號 SYMBOL
J-PP*B

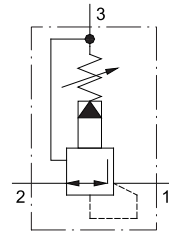

插裝閥尺寸

	a	b		
		L	K	Y
J-PPDB	35	63.8	66.3	80.8
J-PPFB	35	71.4	73.5	88
J-PPHB	46	84	86.2	100.7
J-PPJB	63.5	100.2	102.6	117.1

性能曲線

PERFORMANCE CURVES

調壓曲線

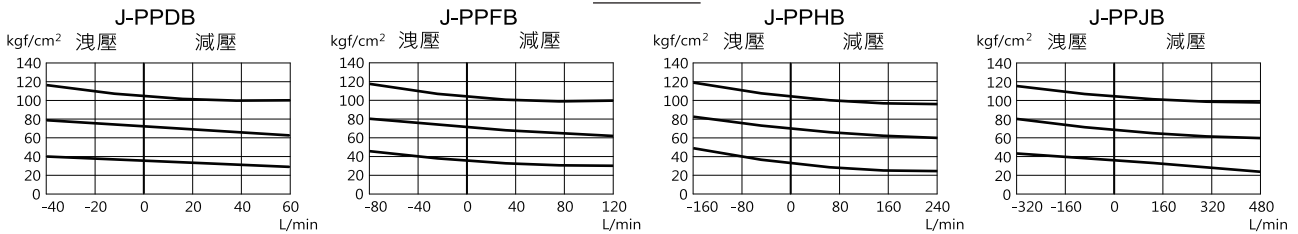

規格說明

SPECIFICATION

型式 MODEL	最高使用壓力 MAX. OPERATING PRESSURE (kgf/cm ²)	最大流量 MAX. FLOW L/min	安裝扭矩 MOUNTING TORQUE N-m	成型孔 CAVITY	重量 WEIGHT kg
J-PPDB	350	40	41-47	T-11A	0.16
J-PPFB		80	61-68	T-2A	0.29
J-PPHB		160	203-217	T-17A	0.57
J-PPJB		320	474-508	T-19A	1.31

型號說明

HOW TO ORDER

J - PPFB - A - L

控制方式 CONTROL
L : 內六角螺桿調整
STANDARD SCREW ADJUSTMENT
K : 旋鈕 HANDKNOB
Y : 三爪旋鈕 TRI-GRIP HANDKNOB

調壓範圍 PRESSURE ADJUSTING RANGE
A : 7-210 kgf/cm² B : 3.5-105 kgf/cm²
C : 10.5-420 kgf/cm² N : 4-55 kgf/cm²
Q : 4-28 kgf/cm² W : 10.5-315 kgf/cm²
※ C為J-PPDB & J-PPHB唯一型式
SPRING C ONLY FOR J-PPDB & J-PPHB

閥規格 VALVE SIZE
PPDB : 40 L/min PPFB : 80 L/min
PPHB : 160 L/min PPJB : 320 L/min

系列編號 SERIES NUMBER